



---

The University of Georgia

---

# Lelon J. Peacock

May 25, 1928 – January 5, 2013

**Roger K. Thomas, PhD**

**Professor Emeritus**

**Department of Psychology**

**[rkthomas@uga.edu](mailto:rkthomas@uga.edu)**

**Web: [faculty.franklin.uga.edu/rkthomas](http://faculty.franklin.uga.edu/rkthomas)**

# Lelon J. Peacock - SEPA 2015



## Early Years

- **Born in Brevard, NC**
- **Three years High School in Berea, KY**
- **Transferred to Lee H. Edwards High School in Asheville, NC**
- **Met and married Marian Davis in 1945, both were 17**
- **Lee studies at Emory University, 1945-1947**
- **Marian studies nursing at Berea College in KY**
- **Lee transfers to Berea College**
- **Earns AB degree in psychology and biology in 1950.**
- **Earns M.S. (1952) and PhD (1956) in Psychology at U. of Kentucky**

## **Peacock's Early Professional Years**

- **U.S. Army Research Laboratory, Fort Knox, KY  
Research Psychophysicist (9/54 - 11/56)**
- **Yale Laboratories of Primate Biology in Orange Park, FL  
Research Associate (11/56 - 04/58)  
Acting Director (05/58 - 08/59)**

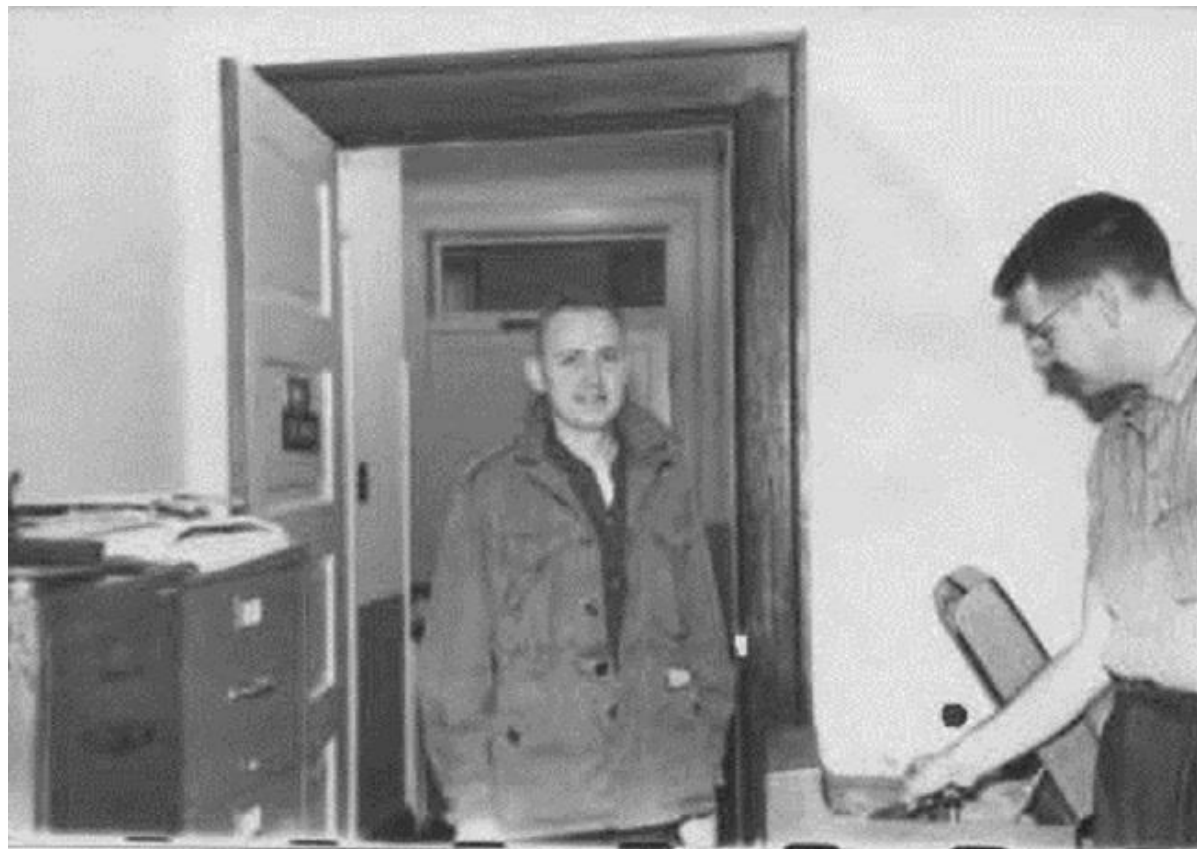

---

The University of Georgia

---

**Lee Peacock and Milton Hodge Circa 1959**

# Peacock's Research Interests

**Four areas appear to encompass most of Lee's research interests**

- 1. *Ionizing Radiation and Behavior...* his Presidential address for the SSPP in 1974.
- 2. Biological bases of motivation; especially hunger motivation and radiation induced taste aversion.
- 3. Human psychophysiology (e.g., expert witness regarding the fallibility of “lie detector” evidence).
- 4. Scientific instrumentation. Three examples.

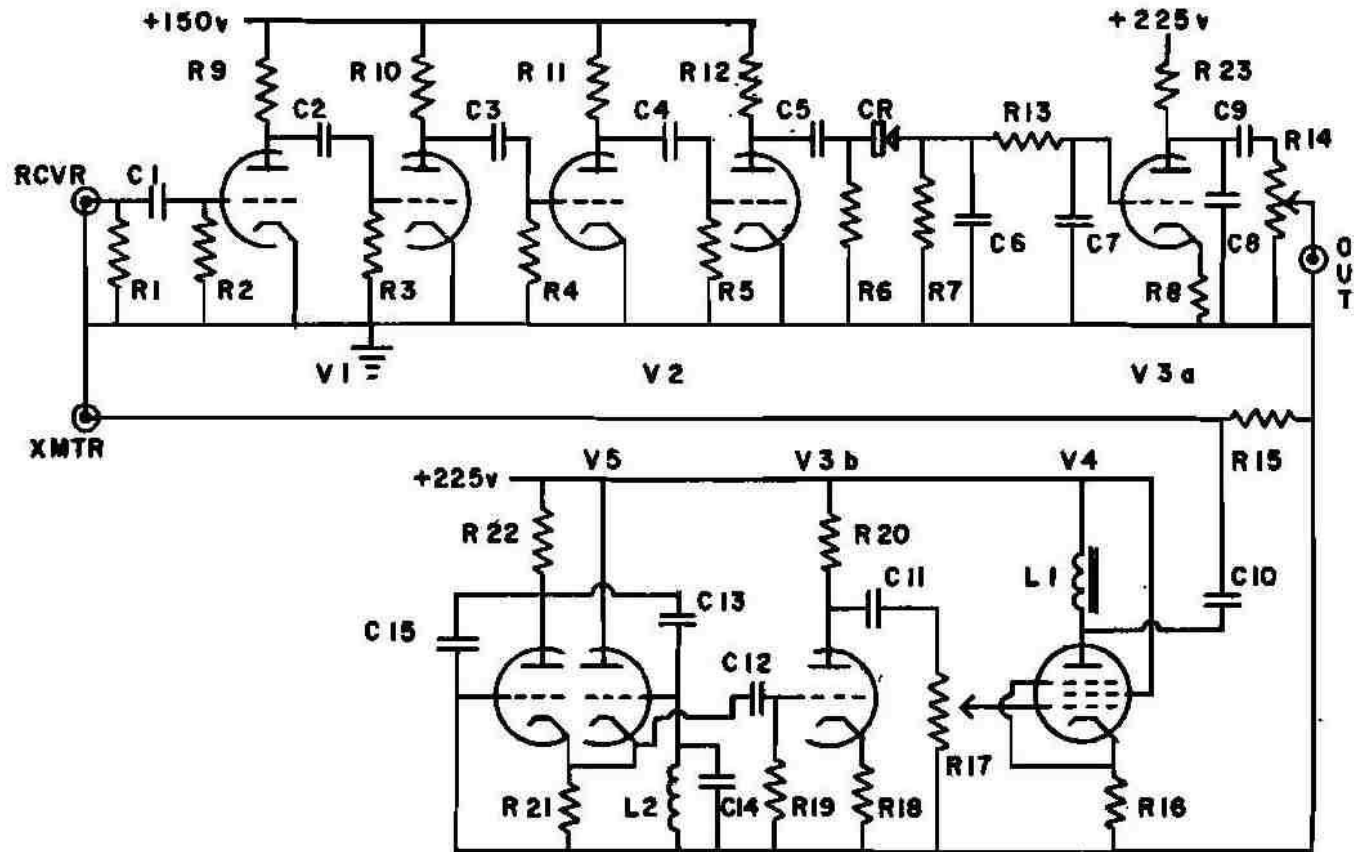

Peacock, L.J. & Williams, W. (1962) An ultrasonic device for recording activity. *American Journal of Psychology*, 75, 648-652

# Measuring the Woodstork's Bill-snap Reflex

## Time Magazine, August 23, 1963\*



The reflex was measured to be 19-thousandths of a second which led **Time** to conclude that the woodstork had “. . .fastest jaws in the drawling South.”

\* Originally published with Philip Kahl in **Nature**.



# Acute Alcohol Intoxication and Female Orgasmic Response

VICTOR J. MALATESTA, ROBERT H. POLLACK,  
TERRI D. CROTTY, AND LELON J. PEACOCK

The article received the **Hugo Beigel Research Award** for the best article of the year in *the Journal of Sex Research* in 1982.

Lee assembled the apparatus to measure the orgasmic response.

## FYI

- The three Blood Alcohol Concentration groups were defined as 0.000%, 0.025%, and 0.075%; every state in the USA uses 0.080% to define DUI or DWI.
- Main finding was that latency to orgasm was increased by alcohol consumption, but the women reported greater sexual arousal and a more pleasurable orgasmic experience.

## Lee Peacock as a Lecturer

*Professor Peacock was a professor's professor. I had the honor--and knew full well my privilege at the time--of being in Prof. Peacock's final regular section of the History of Psychology before he retired. What an amazing experience! One didn't coast through a Peacock class! Or lose interest. I memorized and knew the titles, authors, and key quotations from ALL of about 250 key books that semester (please don't quiz me now!) His "Book of the Day" ritual is something I do at the start of all of my own classes to this day. Dr. Peacock is what we professors of today should strive even harder to be like.*

**Brian R. Metcalf, PhD**  
**Hawaii Pacific University**

## Peacock's Seminars: First of Two Anecdotes

Peacock always students pushed to their limits.

*[One] . . . memory that comes readily to mind ... occurred in his seminar on the Other Senses (all the senses except vision and audition). At the beginning Lee handed out the reading list for the course. As I recall it was some 18 (maybe more) pages. The list didn't simply include research articles, but many books. One that comes to mind was Vol. 3 of the Handbook of Physiology. The whole volume. And there were others. We students talked about how unreasonable this assignment was and since I was Lee's senior assistant I was designated to request him to lighten the load. With trepidation and anxiety I met with Lee and explained how the students in the class thought the reading list was too much and he was unfair to assign it to us. He listened to all the reasons, we were taking other courses, we were engaged in research activities, most of us were either teaching classes or were teaching assistants, etc. After I explained all of this I stated that it was impossible for us to complete that reading list by the end of the term. He paused and then quietly stated, "I know, but I expect you to try."*

Norman Ray Remley, PhD, Professor Emeritus  
Texas Christian University

## Peacock's Seminars: Second of Two Anecdotes

Graduate students in those days were required to pass a competency exam that involved translating research text in one foreign language for the M.S. degree and a second foreign language for the PhD degree. Lee usually mandated that his doctoral students second language would be Russian.

*In the first meeting of Lee's Biological Motivation Seminar and just prior to assigning the topics, Lee asked if there were any "French scholars" in the class. When no one raised a hand, he said, "Well, have any of you passed the French exam?" Having passed the French exam, I reluctantly raised my hand. Lee proceeded to hand me a 120 page monograph, "Les Regulations Psycho-Physiologique de la Faim" by Andre Soulairac that was written entirely in French. I was to prepare a research paper based on this monograph and be ready to report on it the third week! It about killed me but I made it.*

Roger K. Thomas, PhD  
Professor Emeritus  
University of Georgia

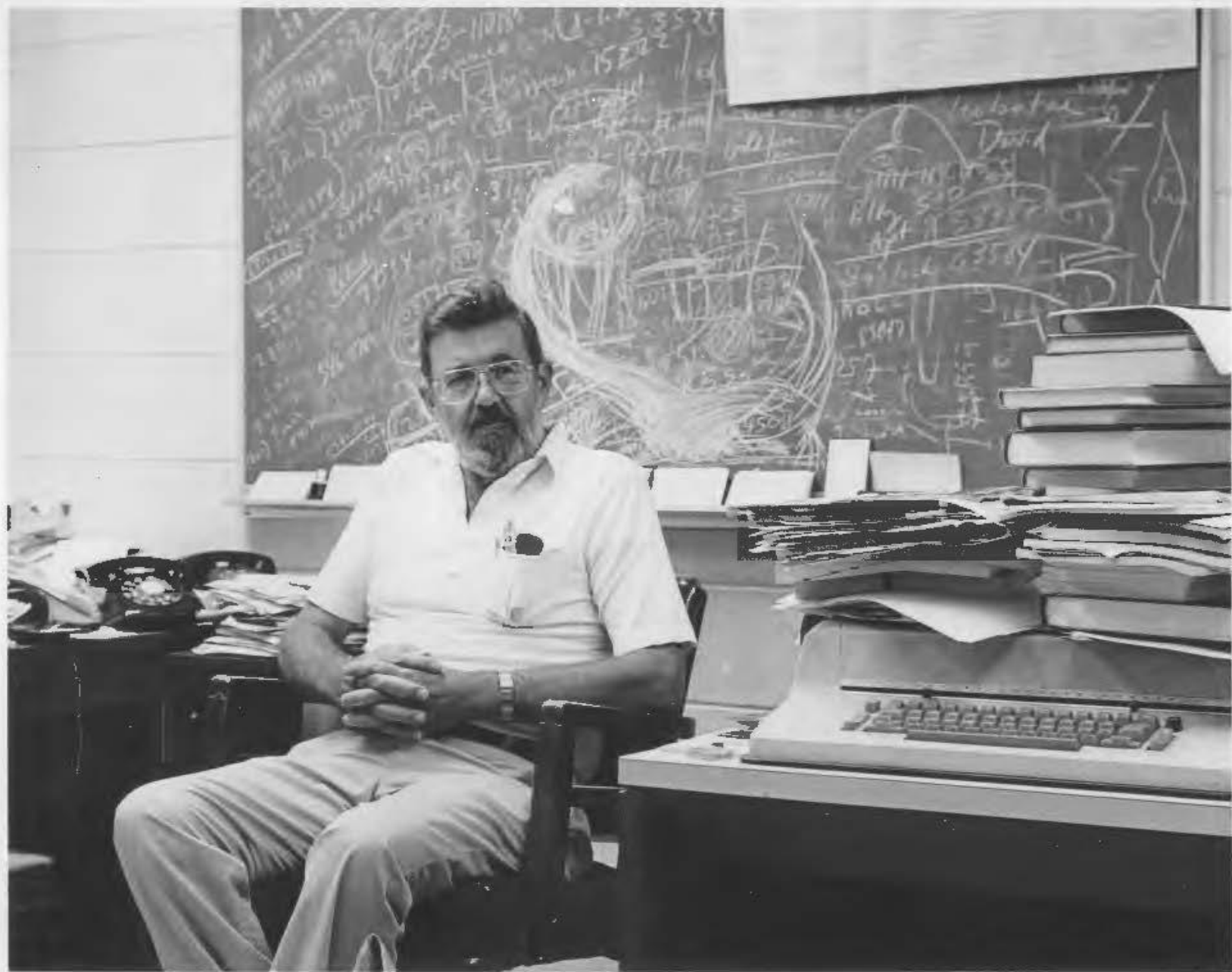

# Lee Peacock as Major Professor to PhD Students

*. . . when studying for my prelims (qualifying exams). I had gone to each member of my committee, and asked if there was anything in particular on which I should focus my attention. Each person gave me relatively concrete pointers. Until Lee. Who said, after slowly pondering for suitable effect, "well (pause again), I suggest you start on the top floor of the science library and work your way down".*

**Note: The UGA Science Library has six floors.**

*. . . when I submitted the first draft of my dissertation to Lee for his comments. This was, of course, done with a combination of fear and pride, having amassed sufficient data to write a draft. After the week had passed, I received back the document (in those days, everything was typed by hand, with carbon copies for critical documents), on which he had scribbled on the front page: "A byzantine farrago of gerundives. Redo". This first sent me running to the library to figure out what he had said, and then to Allen's to drown my sorrow.*

**Ariel Y. Deutch, PhD  
James G. Blakemore Chair in Psychiatry  
Professor of Pharmacology  
Vanderbilt University Medical Center**

# Honors

- M. G. Michael Research Award a university wide award at UGA
- Hugo Beigel Research Award (previously described)
- Fellow, American Association for the Advancement of Science (AAAS)
- President of the Southern Society for Philosophy and Psychology (1974)

# Societies

- American Psychological Association
- AAAS
- Sigma Xi
- Phi Kappa Phi
- Southern Society for Philosophy and Psychology
- Society for Neuroscience
- Society for Psychophysiological Research
- Psychonomic Society.



**Lelon James Peacock, III - 1928-2013**